

A multi axis turret which is equipped with a B-axis control is employed.

The guide bush (G.B.) type and non-guide bush (N.G.B.) type can be changed over according to the workpiece total length.

SWISS TYPE AUTOMATIC LATHE
equipped with star motion control system

SV-20R

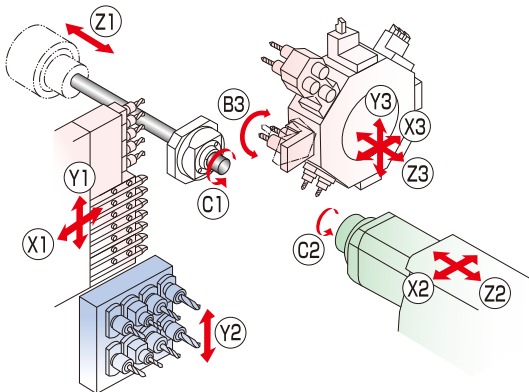

Tool post : G.B. type



The release of the much anticipated version R to the highly successful SV-20 series. This latest addition takes the SV-20 to even greater levels for the manufacture of complex mill turn components.

With such functions as the B-axis control, Y-axis control for backworking and Star Motion Control, the ability to produce prismatic and complex components can be achieved.

① Improved Functions and Machining Ability

- The turret-type tool post can accommodate a 2-spindle type power tool unit with the B-axis control function in a maximum of 4 positions.
- The tool post for backworking has an 8-spindle unit with the Y-axis control as standard, all 8 stations have driven tool capability.
- The ability to mount up to 28 tools in the working area increases machine flexibility.
- The platen power tool motor is increased from 0.5kW (SV-20) to 2.2kW.

② Achievement of Higher Accuracy and Rigidity

- The G.B type and N.G.B. type can be changed over. The N.G.B type incorporates a spindle sleeve slide guideway structure for higher spindle rigidity.
- The motors for the main and sub spindles are a built-in type which improves indexing accuracy.

③ Reduced Machining Time

- The Star Motion Control System ensures a smooth, uninterrupted tool path and reduces the idle time.
- The 8-spindle backworking unit with the Y-axis control function realizes efficient main/back overlap machining to improve cycle times.
- The combination of the gang-type tool post and the turret-type tool post allows simultaneous machining including turning, milling, etc. to contribute to the reduction of cycle time.

Gang edge + 8-position turret + Backworking tool post
The above composition of the tool post reassures enhanced scalability for complex machining with adequate number of tools.

□ Standard Machine Specifications

Item		Specifications
Max. machining diameter		φ20mm(25/32in)
Max. headstock stroke	Standard	205mm(8in)
	R.M.G.B. type	160mm(6-19/64in) : OP
	N.G.B. type	Bar diameter×2.5(Max.50mm)(Max.1-31/32in)
Tool post configuration		Gang type Turning tool + Power-driven tool Turret type 8 stations
Tool	Gang type	6 tools(□16mm), 7 tools(□12mm)
	Turret type	1 tool / station(□16mm), Max.3tools / station(□12mm)
Sleeve	Number of tools	Max.3tools / station
	Max. drilling capability	φ14mm(35/64in)
	Max. tapping capability	M10×P1.5
Power driven attachment	Number of tools	
	Gang type	5 tools
	Turret type	Max.2tools / station(mountable at each 8 positions)
	Max. drilling capability	
	Gang type	φ10mm(25/64in)
	Turret type	φ10mm(25/64in)
Max. tapping capability		
Gang type	M8×P1.25	
Turret type	M8×P1.25	
Spindle speed		
Gang type	Max.8,000min ⁻¹	
Turret type	Max.5,750min ⁻¹	
Drive motor		
Gang type	2.2kw	
Turret type	2.7kw(continuous) / 4.0kw(5min. / 30%ED)	
Rapid feed rate		30m/min(X1,X2,X3,Y1,Z1,Z2,Z3) 20m/min(Y2),15m/min(Y3)
Main spindle indexing angle		C-axis control
Main spindle speed		Max.10,000min ⁻¹
Main spindle motor		3.7kw(continuous) / 5.5kw(10min. / 60%ED)
Coolant tank capability		220ℓ
Dimensions (W×D×H)		2,730×1,350×1,865mm
Center height		1,125mm
Weight		4,150kg
Power consumption		6.3KVA

□ Backworking Attachment Specifications

Item		Specifications
Max. chucking diameter		φ20mm(25/32in)
Max. length for front ejection		105mm(4-9/64in)
Max. parts projection length		75mm(2-61/64in)
Back 8-Spindle unit	Number of tools	
	Stationary tool	8 tools
	Power driven tool	Max.8 tools
	Max. drilling capability	
Stationary tool	φ12mm(1/2in)	
Power driven tool	φ6mm(15/64in)	
Max. tapping capability		
Stationary tool	M10×P1.5	
Power driven tool	M5×P0.8	
Power-driven att. spindle speed		Max.8,000min ⁻¹
Power-driven att. drive motor		1.0kw(continuous) / 1.2kw(5min./30%ED)
Sub spindle indexing angle		C-axis control
Sub spindle speed		Max.10,000min ⁻¹
Sub spindle speed control		AC spindle drive
Sub spindle motor		2.2kw(continuous) / 3.7kw(10min. / 25%ED)

□ External Dimensions

Unit : mm(ft)

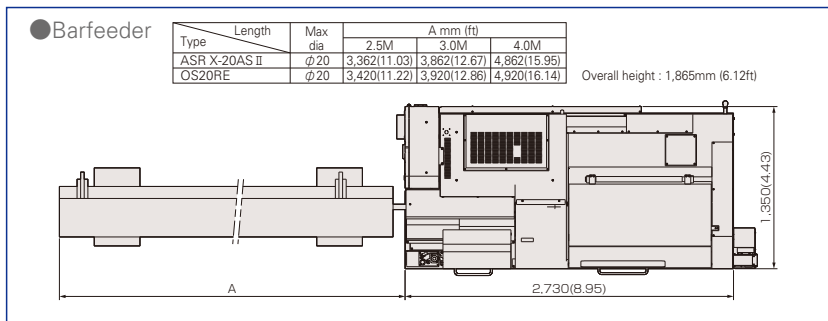

□ Standard Accessories and Functions

- CNC unit FANUC 31i-B5
- Power electric & Operation panel & 10.4-inch color LCD
- Pneumatic unit
- Hydraulic unit
- Spindle cooling unit
- Automatic centralized lubrication system (with level detecting function)
- Cutting oil level (lower limit) detecting unit
- Door interlock system
- Broken cutoff tool detector
- C-axis control (Main / Sub)
- Spindle clamp unit (Main / Sub)
- Drive unit for revolving guide bush
- Revolving guide bush unit
- Main / Sub collet
- Air purge for revolving guide bush
- Sub spindle air purge unit
- Tool holder (Gang-type tool post)
- 5-spindle milling unit (Gang-type tool post)
- Drive system for power-driven attachment (Turret-type tool post)
- Back 8-Spindle unit
- Drive system for power-driven attachment B (Back 8-spindle unit)
- Parts conveyor
- Automatic bar feeder interface
- RS-232C interface
- Work light (for cutting chamber and headstock chamber)
- Leakage breaker

□ Optional Accessories and Functions

- Coolant flow detector
- Parts ejection detector
- Water removal unit
- Beacon
- Non-guide bush type
- Rotary magic guide bush unit
- For pneumatic unit rotary magic guide bush
- Main spindle inner tube
- Parts ejector (Air cylinder type)
- Parts ejector (Spring type)
- Parts ejector with guide tube
- Parts stopper unit
- Coolant unit(6.9MPa / 2.5MPa / 0.7MPa)
- Coolant unit signal cable
- Coolant unit power cable
- Coolant valve
- Coolant pipings
- Manual pulse generator
- Transformer CE marking version
- CE marking version
- Tool Presetter

Note)

The machining capacities apply to SUS303 material. The machining capacities may differ from listed values depending on the machining conditions, such as the material to be machined or the tools to be used.

※ Design features, specifications and technical execution are subject to change without prior notice.

※ This product is an export control item subject to the foreign exchange and foreign trade laws. Thus, before exporting this product, or taking it overseas, contact your STAR MICRONICS dealer.

STAR MICRONICS CO., LTD.

Machine Tools Division

1500-34 Kitanoya, Misawa, Kikugawa, Shizuoka, 439-0023 Japan

America, Europe Sales TEL.+81-537-36-5594 FAX.+81-537-36-5607
Asia Sales TEL.+81-537-36-5574 FAX.+81-537-36-5607

<http://www.star-m.jp/eng/>

9001 | ISO 14001
CERTIFIED

Star CNC Machine Tool Corporation
123 Powerhouse Road, Roslyn Heights, NY 11577, U.S.A.
TEL.+1-516-484-0500 FAX.+1-516-484-5820

Star Micronics GB Limited
Chapel Street, Melbourne, Derbyshire DE73 8JF, U.K.
TEL.+44-1332-86-44-55 FAX.+44-1332-86-40-05

Star Micronics GmbH
Robert-Grob-Str. 1, D-75305 Neuenburg, Germany
TEL.+49-7082-7920-0 FAX.+49-7082-7920-20

Star Micronics AG
Lauetstrasse 3, CH-8112 Otelfingen, Switzerland
TEL.+41-43-411-60-60 FAX.+41-43-411-60-66

Star Machine Tool France
90 Allee de Glaisy, ZI 74300 Thyez Haute Savoie, France
TEL.+33-450-96-05-97 FAX.+33-450-96-91-54

Shanghai Xingang Machinery Co., Ltd.
2F, 229 Fute Rd. N. The China (Shanghai) Pilot Free Trade Zone
TEL.+86-21-5868-2100 FAX.+86-21-5868-2101

Star Micronics (Thailand) Co., Ltd.
289/23 M.13 Soi Kingkaew 25/1, Kingkaew Rd., T.Rachathewa A. Bangplee Samutprakarn 10540, Thailand
TEL.+66-2-186-8945-47 FAX.+66-2-183-7845

2016.02_Ver1.0_1